

Product data sheet

Characteristics

XZCR1502040G2

Jumper cable XZ, male straight M12 3 pin, female elbowed Ø 8 mm 3 pin, PUR 2 m



Product availability: Non-Stock - Not normally stocked in distribution facility

Price*: 42.15 USD



Main

| | |
|------------------------------------|-------------------|
| Accessory / separate part category | Cabling accessory |
| Accessory / separate part type | Jumper cable |

Complementary

| | |
|-------------------------------------|--------------------------------------|
| Jumper cable end 1 | M12 male 3 pins straight screw-on |
| Jumper cable end 2 | Ø 8 mm female 3 pins elbowed clip-on |
| Cable composition | 3 x 0.34 mm ² |
| Cable length | 6.56 Ft (2 m) |
| Wire insulation material | PUR |
| Cable outer diameter | 0.20 In (5.2 mm) |
| [Ue] rated operational voltage | 60 V AC 75 V DC |
| Line Rated Current | 4 A |
| Insulation resistance | >= 1000 MOhm |
| Maximum resistance across terminals | 5000 MOhm |
| Net weight | 0.18 Lb(US) (0.08 kg) |

Environment

| | |
|---------------------------------------|---|
| IP degree of protection | IP67 |
| Product certifications | CULus |
| Ambient air temperature for operation | -31...194 °F (-35...90 °C) static 23...194 °F (-5...90 °C) flexing |
| Ambient air temperature for storage | -31...212 °F (-35...100 °C) |

Ordering and shipping details

| | |
|-----------------------|------------------------|
| Category | 22483 - MACHINE CABLES |
| Discount Schedule | DS3 |
| GTIN | 03389110762631 |
| Nbr. of units in pkg. | 1 |
| Package weight(Lbs) | 2.47 Oz (70 g) |
| Returnability | No |
| Country of origin | CZ |

Packing Units

| | |
|------------------------------|-----------------------|
| Unit Type of Package 1 | PCE |
| Package 1 Height | 1.18 In (3 cm) |
| Package 1 width | 7.87 In (20 cm) |
| Package 1 Length | 7.87 In (20 cm) |
| Unit Type of Package 2 | S02 |
| Number of Units in Package 2 | 40 |
| Package 2 Weight | 6.99 Lb(US) (3.17 kg) |
| Package 2 Height | 5.91 In (15 cm) |
| Package 2 width | 11.81 In (30 cm) |
| Package 2 Length | 15.75 In (40 cm) |

Offer Sustainability

| | |
|----------------------------|---|
| Sustainable offer status | Green Premium product |
| California proposition 65 | WARNING: This product can expose you to chemicals including: Diisononyl phthalate (DINP), which is known to the State of California to cause cancer, and Di-isodecyl phthalate (DIDP), which is known to the State of California to cause birth defects or other reproductive harm. For more information go to www.P65Warnings.ca.gov |
| REACH Regulation | REACH Declaration |
| EU RoHS Directive | Pro-active compliance (Product out of EU RoHS legal scope) EU RoHS Declaration |
| Mercury free | Yes |
| RoHS exemption information | Yes |
| Environmental Disclosure | Product Environmental Profile |
| Circularity Profile | End Of Life Information |

Contractual warranty

| | |
|----------|-----------|
| Warranty | 18 months |
|----------|-----------|

Dimensions

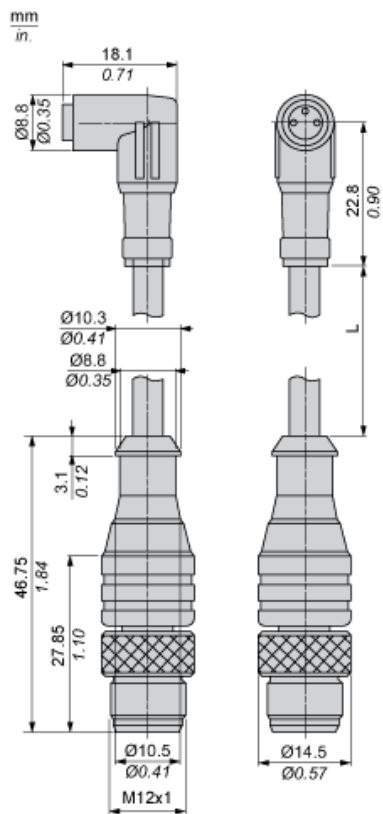

L : Length of cable

Connections and Schemes

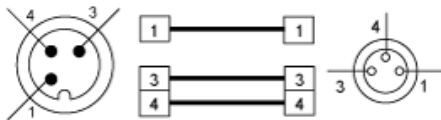

Product Life Status : Commercialised